

AMPERE  **EV**

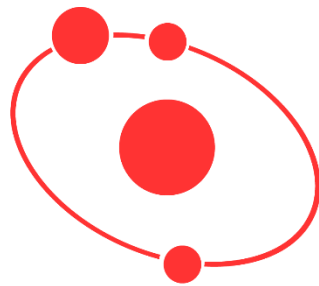

ATOM
DRIVE SYSTEM

Cascadia Motion IM-225 Integrated Module

Electric Motor

Ampere EV



CONTENTS

- Main Features 3
- Mounting Dimensions 4
 - Front Dimension..... 4
 - Rear Dimension 5
 - Left Dimension 6
 - Right Dimension 7
- Inverter to Motor, Low Voltage Connections 8
- Oiling Information 9



Main Features

The Ampere EV Atom Drive System is designed to work the first time, every time. To help maintain this to be true, the Atom Drive System utilizes the Cascadia Motion IM-225 Integrated Module Electric Motor. This motor packs a serious punch in a compact package. With a peak power rating of 225kW, equaling 302Hp, this compact motor is designed to perform under almost any condition.



Main Features

480VDC Maximum voltage

Integrated oil pump

Integrated water pump

Integrated oil cooler

Shallow sump depth (170mm from bottom)

300mm axial length and 405mm total height

Auxiliary ports for optional oil connections

Three transmission connection bolt patterns

Main Specifications

Peak Torque 500Nm

Peak Power 225kW

Continuous Power 110-135kW

Maximum Speed 12000rpm

Weight 64kg

Motor Cooling Medium Dexron VI

Inverter Cooling Medium 50% E.G. / 50% Water

Combined Efficiency 95% peak (@200Nm, 5500 rpm)



Mounting Dimensions

Front Dimension

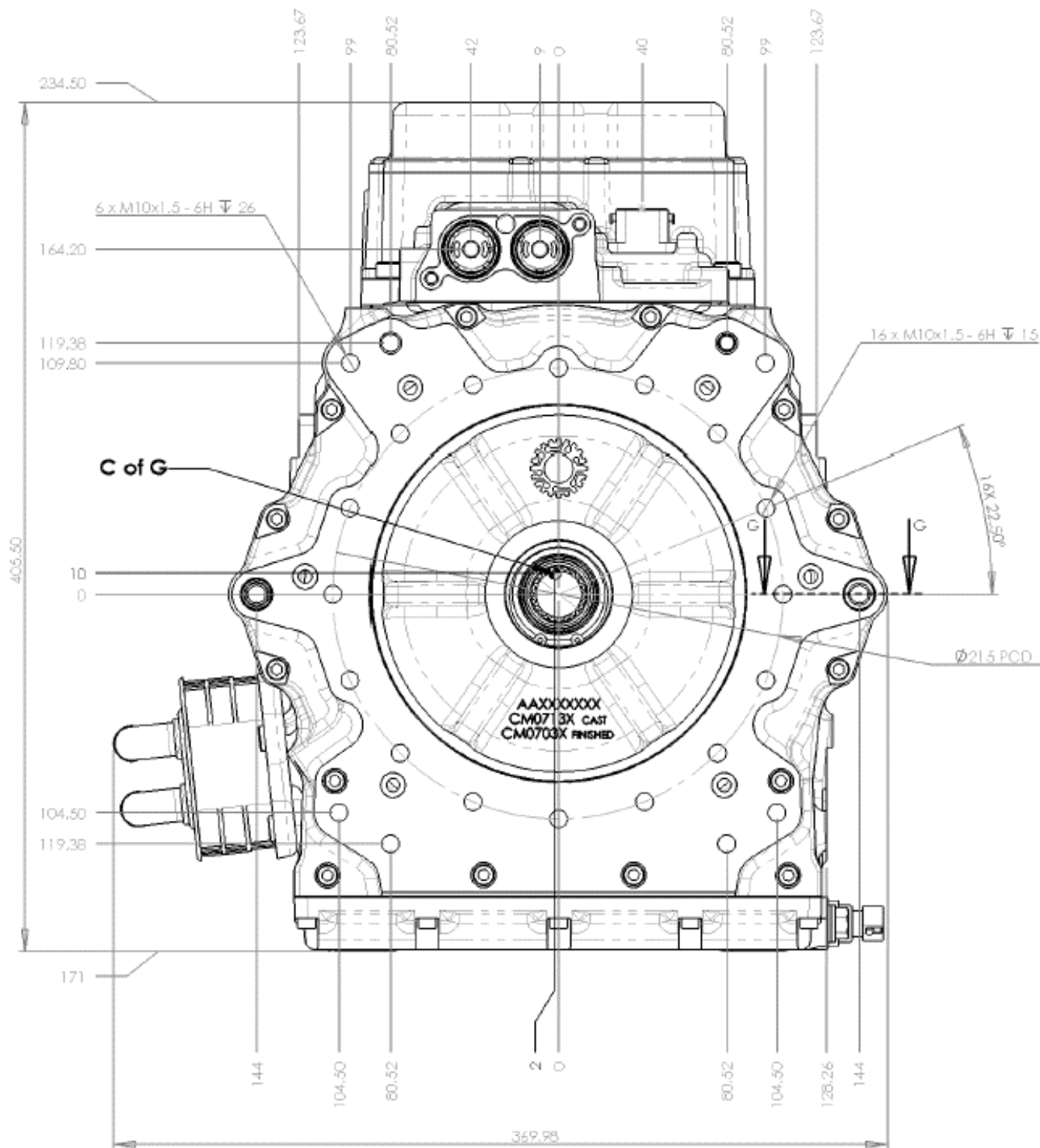



Rear Dimension

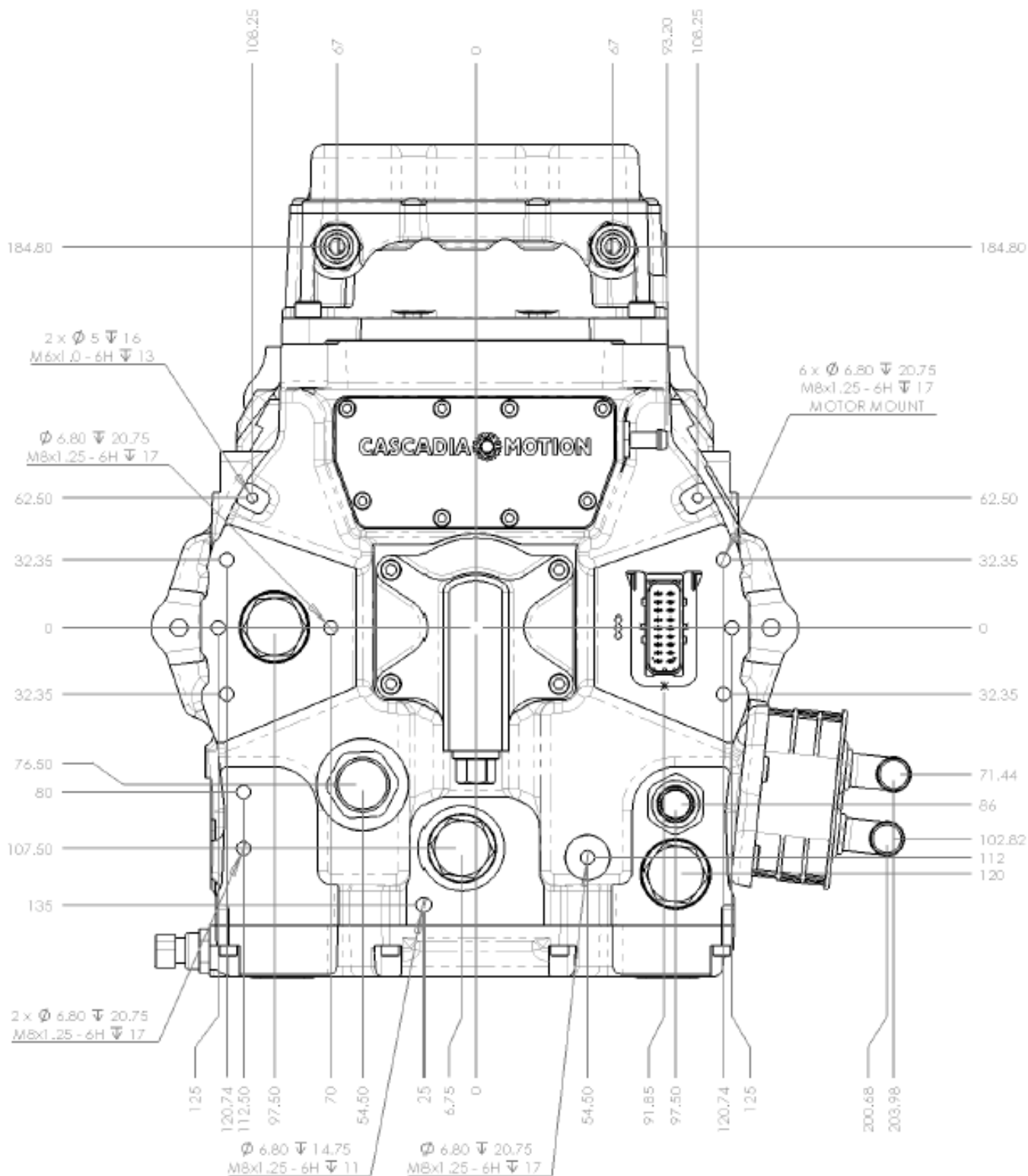



Left Dimension

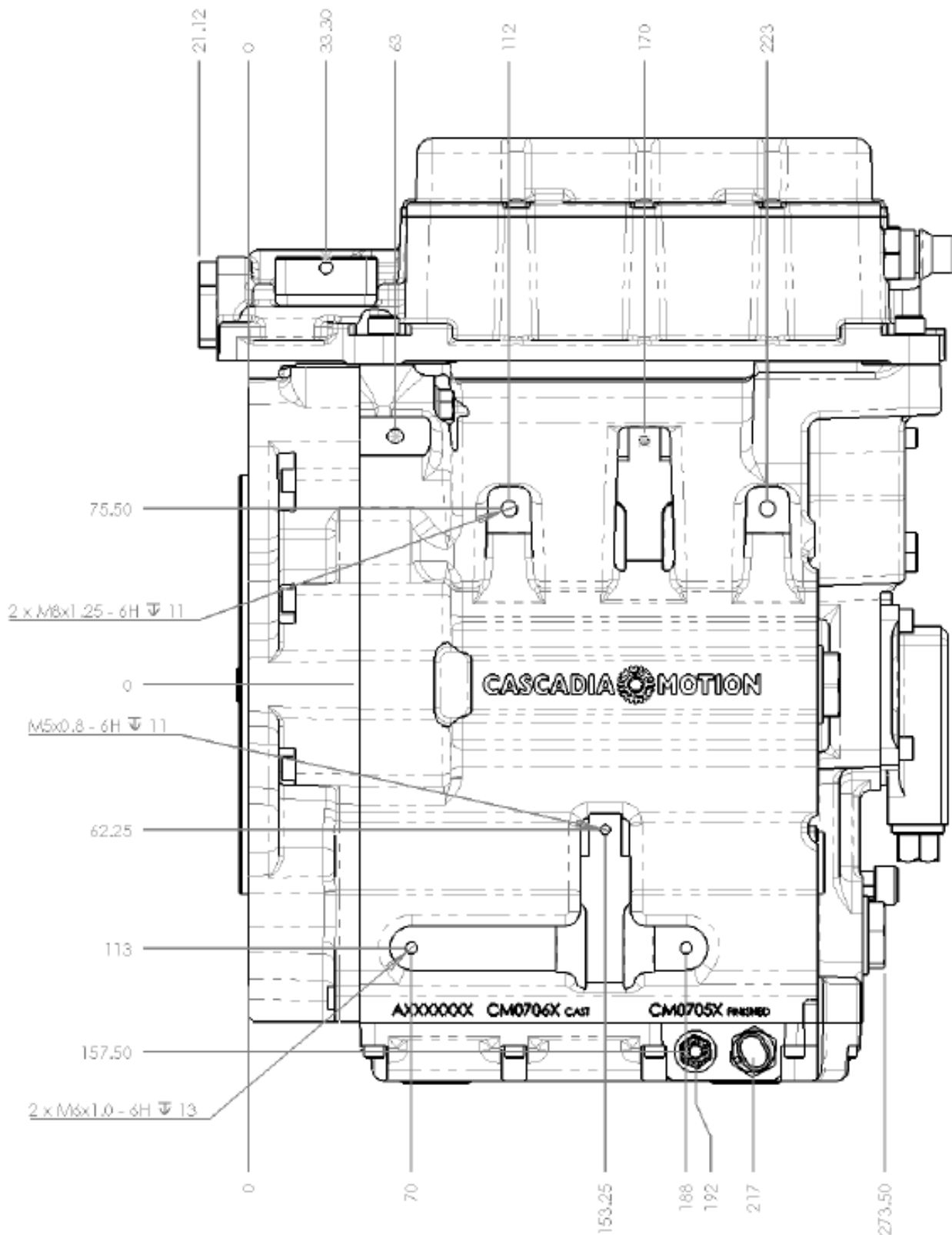



Right Dimension

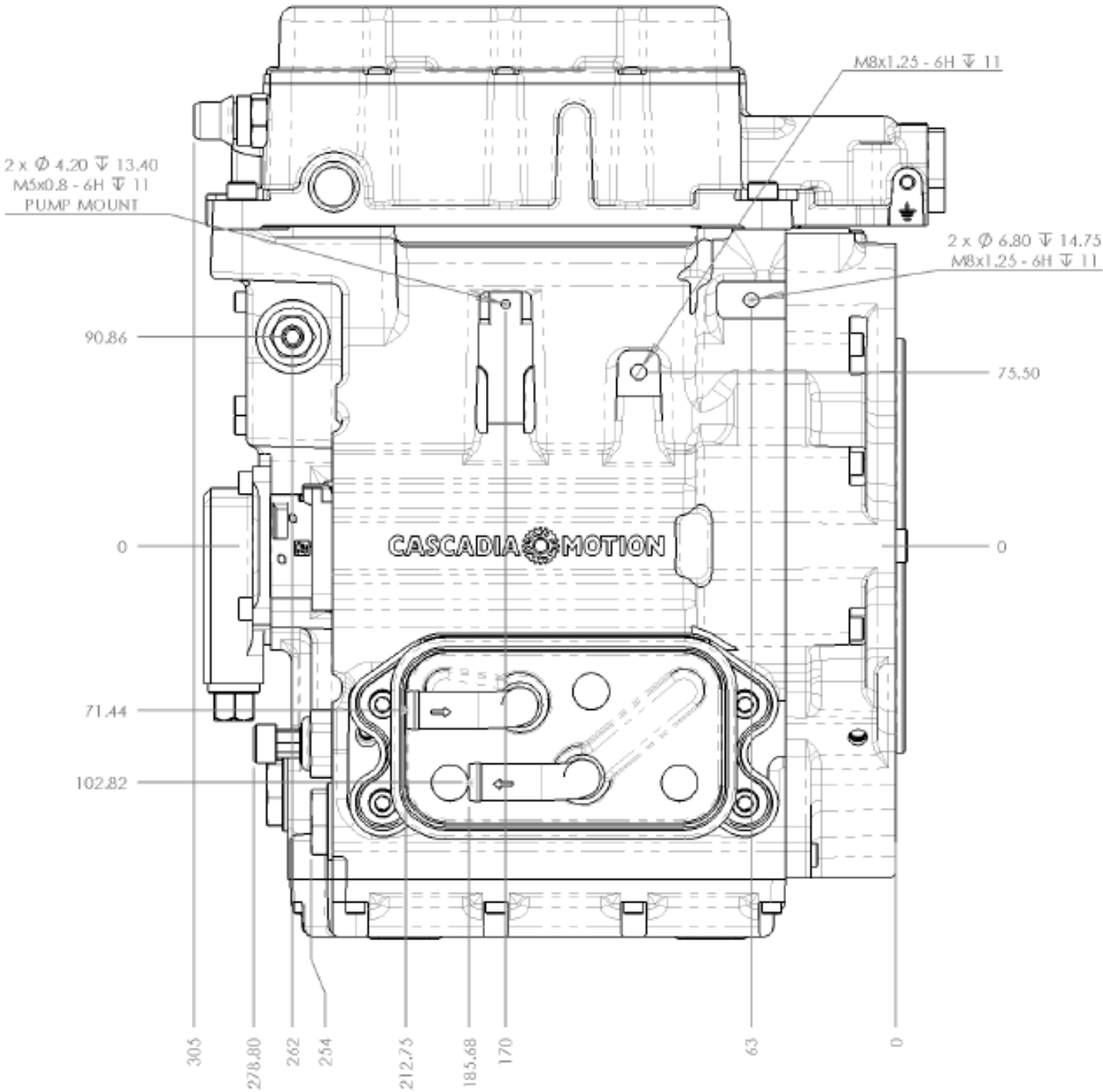



Inverter to Motor, Low Voltage Connections

Motor Pin	Function	CM200DX or DZ Pin
9	Temperature Sensor #1 (AIN2)	C4
18	Temperature Sensor #1 (AGND)	A4
8	Temperature Sensor #2 (AIN3)	DX-D; D4; DZ-S
17	Temperature Sensor #2 (AGND)	DX-D; D4; DZ-S
5	Resolver Shield Ground	G1
6	N/C	N/C
3	Resolver Signal Cos Low, /Cos	C1
12	Resolver Signal Cos Hi, Cos	D1
2	Resolver Signal Sin Low, /Sin	A1
11	Resolver Signal Sin Hi, /Sin	B1
1	Resolver Excitation Negative Signal, /EXC	F1
10	Resolver Excitation Positive Signal, /EXC	E1
Shield	Resolver Shield Ground	G1



Oiling Information

All IM225 units are shipped filled with oil. Procedures below for reference.

Approved Oils

Dexron VI ATF (preferred)

Transynd ATF (Synthetic Formulation of Dexron VI Made by Mobil 1)

Shell Spirax S6 ATF A295 (made by Shell for ATF Application)

Lubrizol OS183539V

BASF (manual transmission fluid)

Oil Fill Procedure

1. Remove drain plug and drain motor of oil
2. Install drain plug. Torque to 20 Nm (15ft lbf)
3. Remove oil fill cap. Torque to 20 Nm (15ft lbf)
4. Fill with 1.8 L of approved oil.
5. Install oil fill cap. Torque to 20 Nm (15ft lbf)
6. Inspect sight glass to verify oil is present.
7. Spin motor to circulate the oil
8. Oil level in sight glass to be observed at $\frac{1}{4}$ - $\frac{1}{2}$ on level ground after spin.

Oil Pump Note

Unless otherwise specified, the pump components will be installed so that oil is pumping when the motor is rotating counterclockwise. Oil will not pump when the motor is rotating clockwise; However, it is approved to spin the motor in reverse rotation for short duration events.

